

ELECTRICAL NETWORK ANALYZER



CE

1826 NA

FEATURES

- Measures Earth Resistance without the need for poles in the ground or external measuring wires.
- Earth Measurement uses the real earth current path and the current generated by the electric network, without the need for any disconnection.
- The Earth Resistance displayed is exactly the earth resistance, that the earth current will need to go through is an earth fault occurs. (you do not need to add all the bonding points and connection paths resistances)
- Displays voltage supply at the transformer (Line to Neutral), without loading the transformer. Displays voltage between Line (Phase) and Earth (Ground), without drawing any current.
- Measures the Impedance of the Line itself, so you can analyzes and differentiate between the multiples paths of the wiring.
- Measures the Neutral Impedance. Single One Smart Push button operation; ON, Test, Scroll trough results and menus.
- Checks wiring integrity(LEDs).
- Auto-off/auto-ranging (software ranging). Microprocessor controlled.
- Combined Prospective Short circuit Current, Loop, individual wire and Earth Tester.
- Voltage test L-N and L-E.
- Loop test for L-E and L-N and PSC.
- Enables analysis of constituent components in L-E and L-N loops giving resistance of earth, neutral wire, live wire and transformer winding.
- The display can be customized for large orders.
- EN/IEC 61010-1 CAT III 300V



The 1826NA is the first portable electrical network analyzer. It is a built-in Earth tester which does not require the use of poles or long wires. **This instrument is useful for fault-finding or commissioning of electrical installations.** Differentiation between the Line (hot), Neutral and Earth (ground) path by reading their values has never been so easy. Bad contacts, old wiring or bad earth path are quickly identified. Faulty electrical network can be resolved in a fraction of the time normally required using conventional equipment. Down time due to a faulty electrical network is minimal as the fault can be identified and diagnosed quickly. Find which wire need to be attended to and why (find those old wires with high impedance before a fire starts, and replace them). **The complete electrical network can be analyzed by scrolling through the results.**

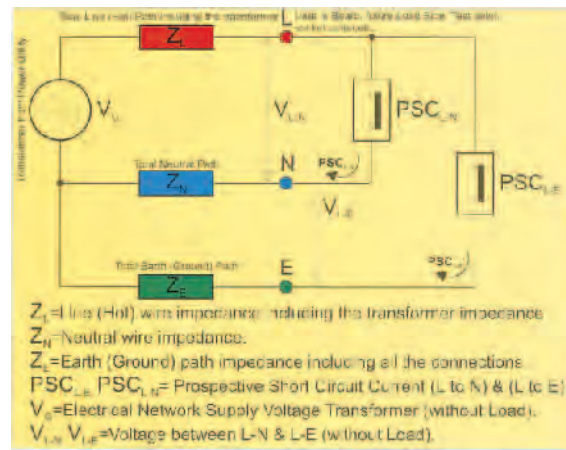

SPECIFICATIONS

Loop Impedance Range L-E, L-N	0.03-2000 Ω (Software Ctrl)
Test Currents in Each Loop	11.76A at 230V/50Hz
Voltage Measurement L-N, L-E	50 to 280V AC (Sine)
Earth wire/path Return Resistance	0.01-2000 Ω (Software Ctrl)
Neutral Wire Resistance	0.01-2000 Ω (Software Ctrl)
Line Wire Resistance & Transformer Windings	0.01-2000 Ω (Software Ctrl)
PSC Current (L-N) Max	6kA at 230Vac supply
PSC Current (L-E) Max	6kA at 230Vac supply
Operating Voltage	230V \pm 20 at 50Hz Sine
Typical Accuracy	
Loop Impedance	4%rdg \pm 2dgt
PSC Current	10%rdg \pm 5dgt
Voltage	2%rdg \pm 1dgt
Operating - Temperature - Humidity	-10 $^{\circ}$ C to +40 $^{\circ}$ C 80% max relative humidity
Dimensions (LxWxD)	(170x165x92)mm
Weight	970g Approx.
Power Source	1.5V(AA)x8 Batteries
Accessories	Test leads (AL-34) Shoulder belt Instruction manual Batteries

STANDARD ELECTRIC WORKS CO., LTD.

NO.106, SU WEI ROAD, PAN CHIAO, TAIPEI HSIEN, TAIWAN, R.O.C.

TEL: 886-2-22563125 FAX: 886-2-22556352 886-2-82573518

http://www.sew.com.tw e-mail: sales@sew.com.tw e-mail: sew@ms10.hinet.net